

THIS DOCUMENT IS A COPY AND IS NOT THE SOURCE DOCUMENT. INFORMATION IS SUBJECT TO CHANGE WITHOUT NOTICE. THE INFORMATION CONTAINED HEREIN IS COPYRIGHTED BY HAROLD BECK AND SONS, INC. CHANGES TO THE DOCUMENT ARE PROHIBITED. CONTACT A BECK SALES ENGINEER IF A CERTIFIED DRAWING IS REQUIRED.

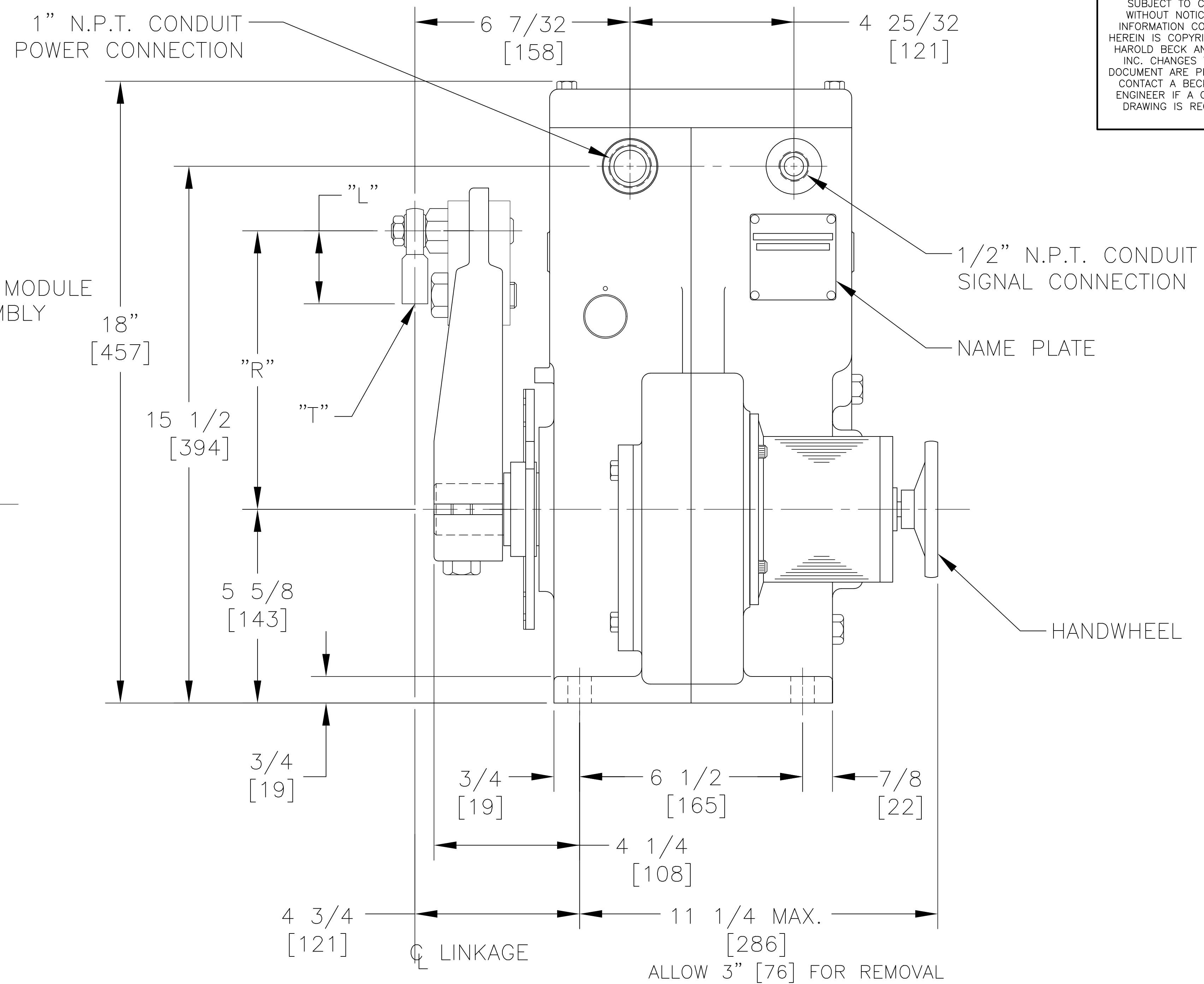
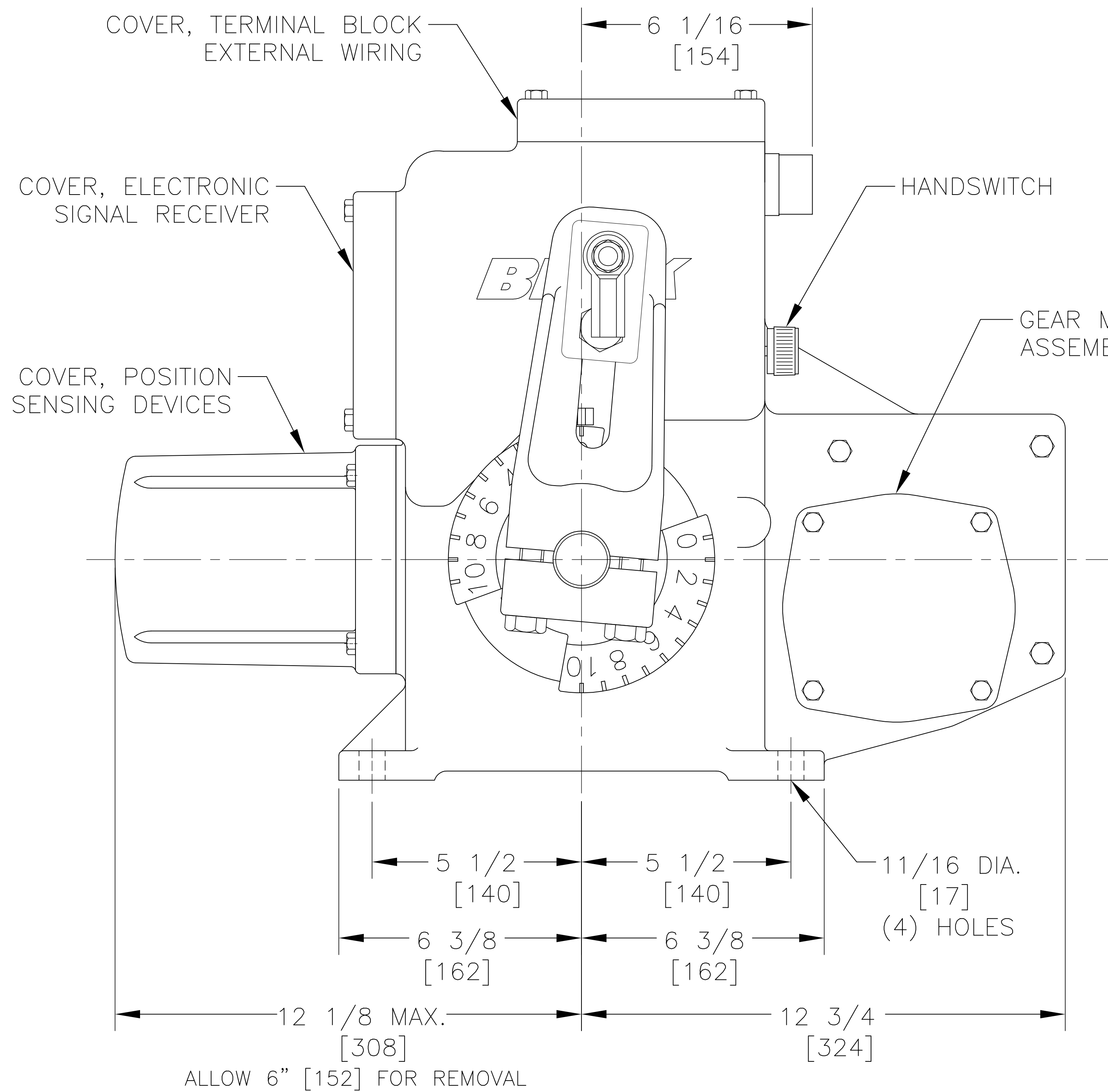

BECK DRIVE MODEL NO.	TORQUE RANGE	APPROX. WEIGHT	OUTPUT SHAFT DIA.	CRANKARM & SWIVEL SUPPLIED AS STANDARD				MAXIMUM OVERHUNG LOAD
				CRANKARM PART NO.	CRANKARM RADIUS (ADJUSTABLE) "R" DIM.	SWIVEL LENGTH "L" DIM.	SWIVEL INTERNAL THREAD "T" DIM.	
11-200	125 TO 250 LB.-FT. 169 TO 339 Nm	120 LBS. 54 KGS.	1 1/2 [38]	14-7330-26	3-1/2 TO 8 [89 TO 203]	2-1/8 [54]	1/2-20 x 1-3/16 [30]	3000 LBS. 1361 KGS.

RECOMMENDED SCREW TORQUES

	SIZE (IN.)	TORQUE (LB-FT)	TORQUE (Nm)
CRANK ARM SCREW	5/8-18	240	325
CRANK PIN SCREW/STUD	3/4-16	300	407
CRANK PIN SCREW	3/4-16	300	407
ROD END LOCK NUT	1/2-20	35	47
BODY SCREWS	3/8-16	20	27
BODY SCREWS	1/2-13	50	68
COVER SCREWS	5/16-18	10	14
MOTOR SCREWS	1/4-20	6	8
GEAR MODULE SCREWS	5/16-18	10	14

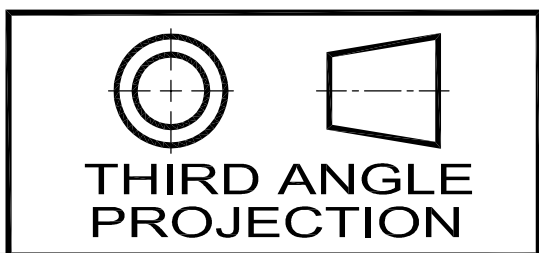

TOLERANCES:
 OUTLINE DIMENSIONS ±1/4 [±6]
 MOUNTING DIMENSIONS ±1/16 [±2]

ALL DIMENSIONS ARE IN INCHES AND [MM] UNLESS OTHERWISE SPECIFIED.
 THREADS AND TAPPED HOLES ARE SPECIFIED AS UNIFIED THREAD SIZES ONLY.
 CONDUIT PIPE THREADS PER AMERICAN NATIONAL STANDARD TAPER PIPE THREADS (N.P.T.)

18-0200-01o

HAROLD BECK & SONS INC
 NEWTOWN INDUSTRIAL COMMONS NEWTOWN, PENNSYLVANIA 18940 USA

TITLE: **OUTLINE DIMENSIONS BECK 11-200 DRIVE**

DRAWN: DWK 10-23-07	SCALE: NONE	DRAWING NO: 18-0200-01o	REV: E
CHECKED: GMD 10-24-07			
APPROVED: JHM 10-26-07		SHEET NO. 1 OF 1	

SIZE: **D**