

THIS DOCUMENT IS A COPY AND IS NOT THE SOURCE DOCUMENT. INFORMATION IS SUBJECT TO CHANGE WITHOUT NOTICE. THE INFORMATION CONTAINED HEREIN IS COPYRIGHTED BY HAROLD BECK AND SONS, INC. CHANGES TO THE DOCUMENT ARE PROHIBITED. CONTACT A BECK SALES ENGINEER IF A CERTIFIED DRAWING IS REQUIRED.

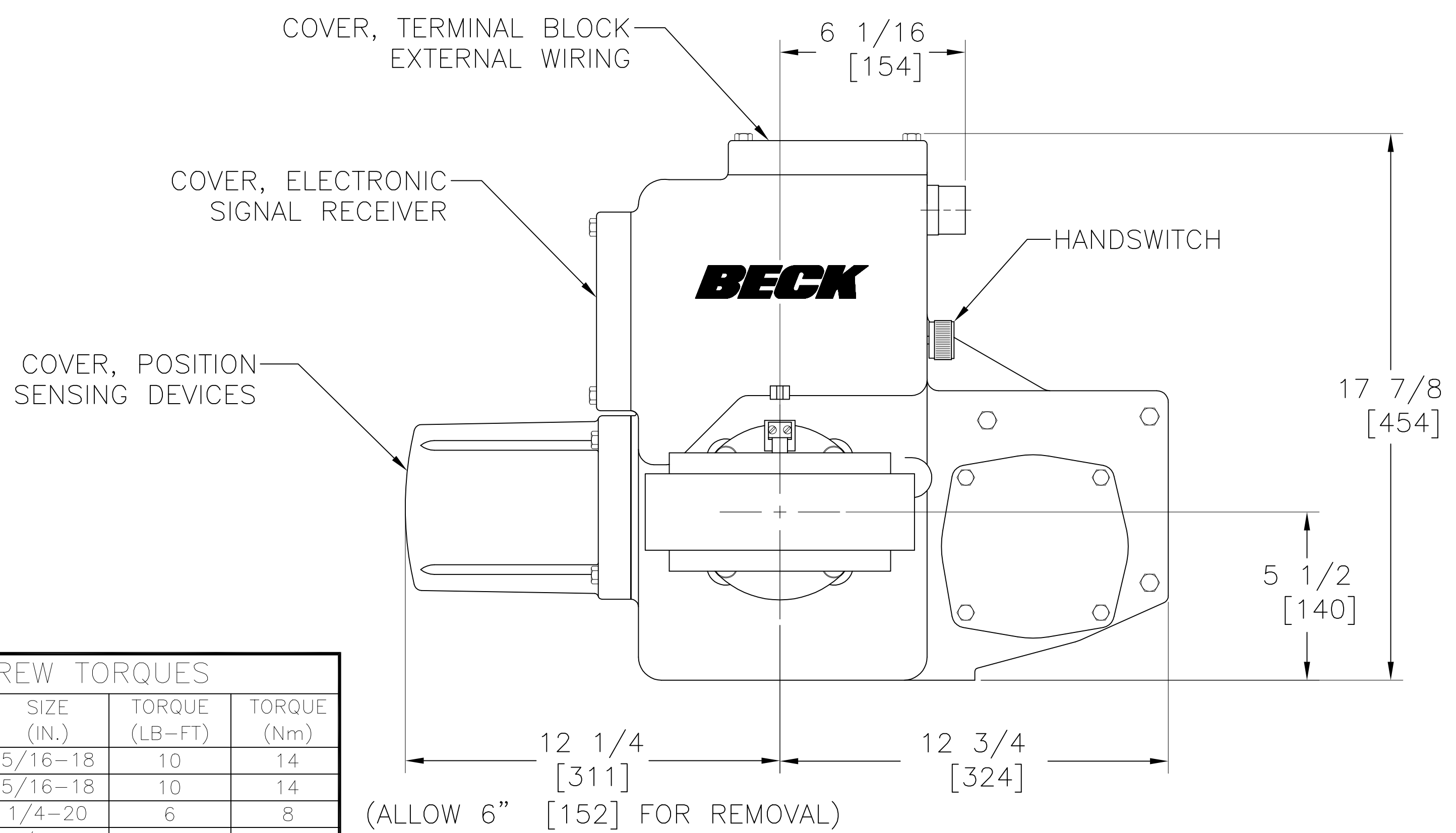
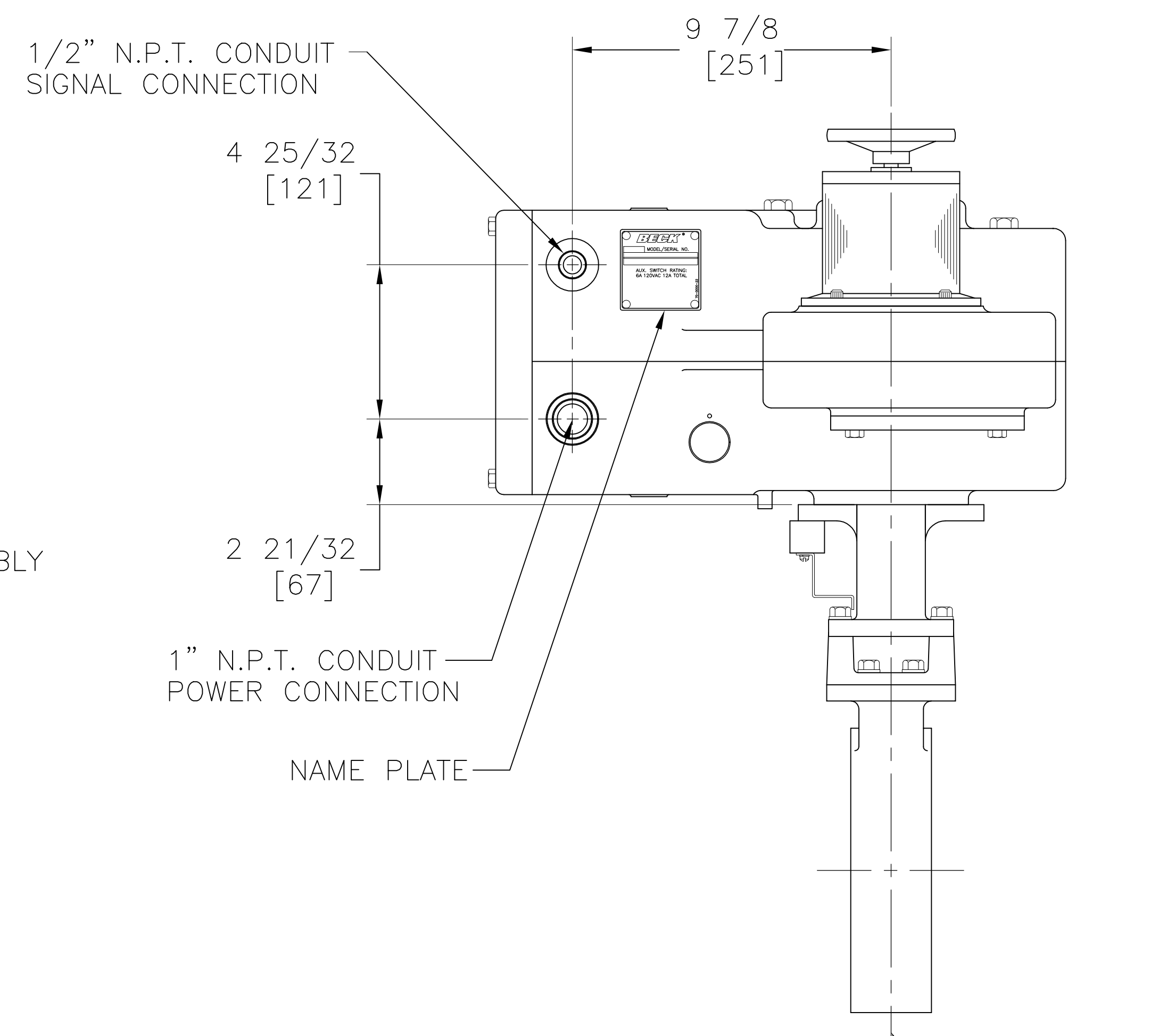
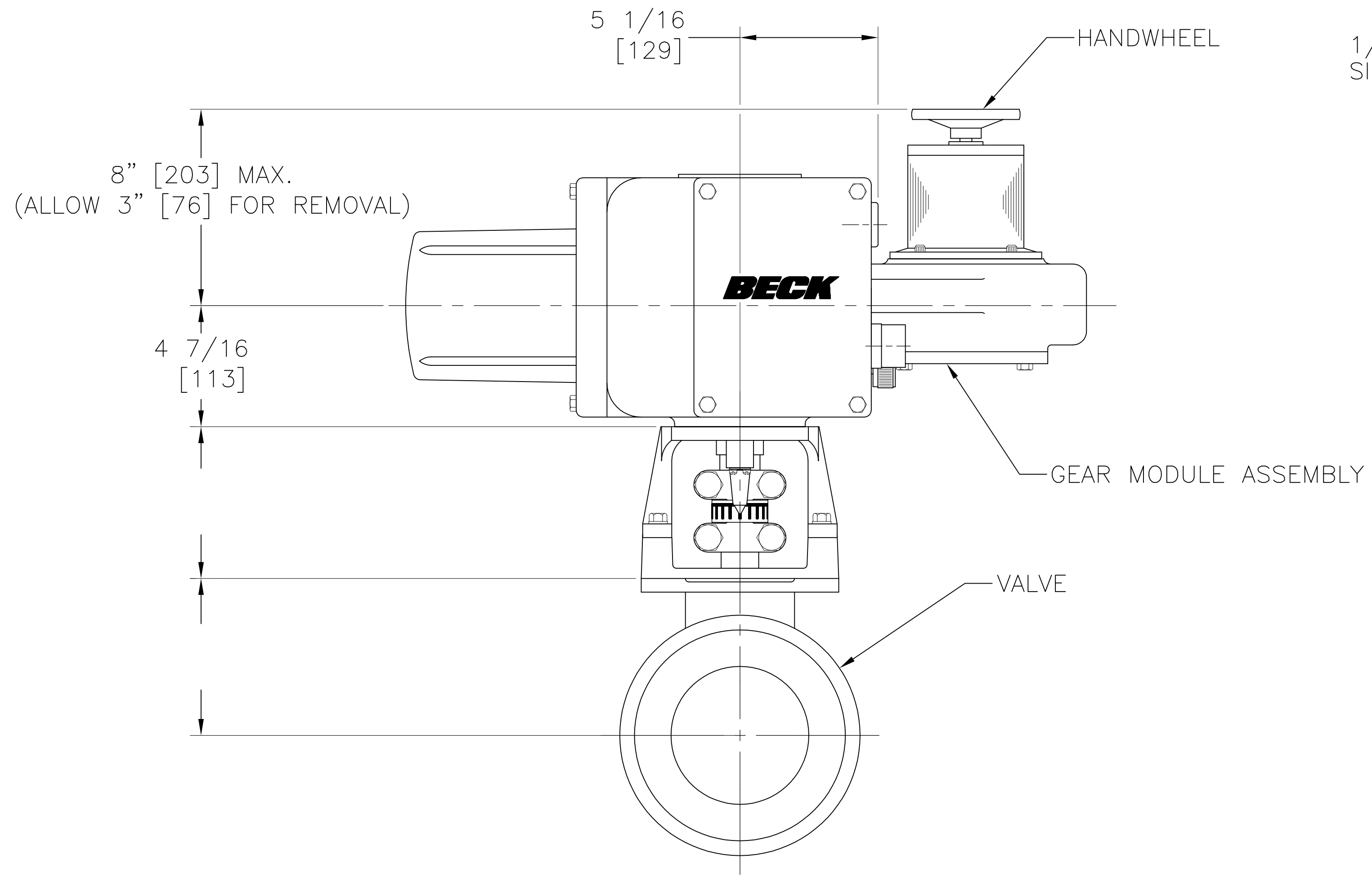

**NOTES:**

ALL DIMENSIONS ARE TYPICAL.  
TOLERANCES:  $\pm 1/4$  [ $\pm 6$ ]

\*SCREW TORQUES FOR MOUNTING HARDWARE WILL BE SUPPLIED WITH SPECIFIC VMS.

DRIVE MAY BE ROTATED AROUND THE VALVE IN 90° INCREMENTS.

ALL DIMENSIONS ARE IN INCHES AND [MM] UNLESS OTHERWISE SPECIFIED. THREADS AND TAPPED HOLES ARE SPECIFIED AS UNIFIED THREAD SIZES ONLY. CONDUIT PIPE THREADS PER AMERICAN NATIONAL STANDARD TAPER PIPE THREADS (N.P.T.)

RECOMMENDED SCREW TORQUES			
	SIZE (IN.)	TORQUE (LB-FT)	TORQUE (Nm)
COVER SCREWS	5/16-18	10	14
GEAR MODULE SCREWS	5/16-18	10	14
MOTOR SCREWS	1/4-20	6	8
BODY SCREWS	3/8-16	20	27
BODY SCREWS	1/2-13	50	68
CONTROL END COVER SCREWS	5/16-18	10	14
COUPLING SCREWS	5/8-18	170*	230*
MOUNTING BRACKET SCREWS (FLAT HEAD)	3/8-16	25	34

18-0260-02o

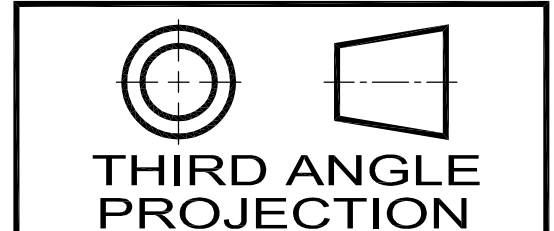

<b>HAROLD BECK &amp; SONS INC</b> <small>NEWTOWN INDUSTRIAL COMMONS NEWTOWN, PENNSYLVANIA 18940 USA</small>			
TITLE: <b>OUTLINE DIMENSIONS FOR UNITIZED ASSEMBLIES OF A BECK 11-260 DRIVE AND A TYPICAL VALVE</b>			
DRAWN: DWK 11-8-07	SCALE: NONE	DRAWING NO: <b>18-0260-02o</b>	REV: <b>F</b>
CHECKED: GMD 11-9-07		SHEET NO. 1 OF 1	
APPROVED: JHM 11-12-07			

SIZE: D