

THIS DOCUMENT IS A COPY AND IS NOT THE SOURCE DOCUMENT. INFORMATION IS SUBJECT TO CHANGE WITHOUT NOTICE. THE INFORMATION CONTAINED HEREIN IS COPYRIGHTED BY HAROLD BECK AND SONS, INC. CHANGES TO THE DOCUMENT ARE PROHIBITED. CONTACT A BECK SALES ENGINEER IF A CERTIFIED DRAWING IS REQUIRED.

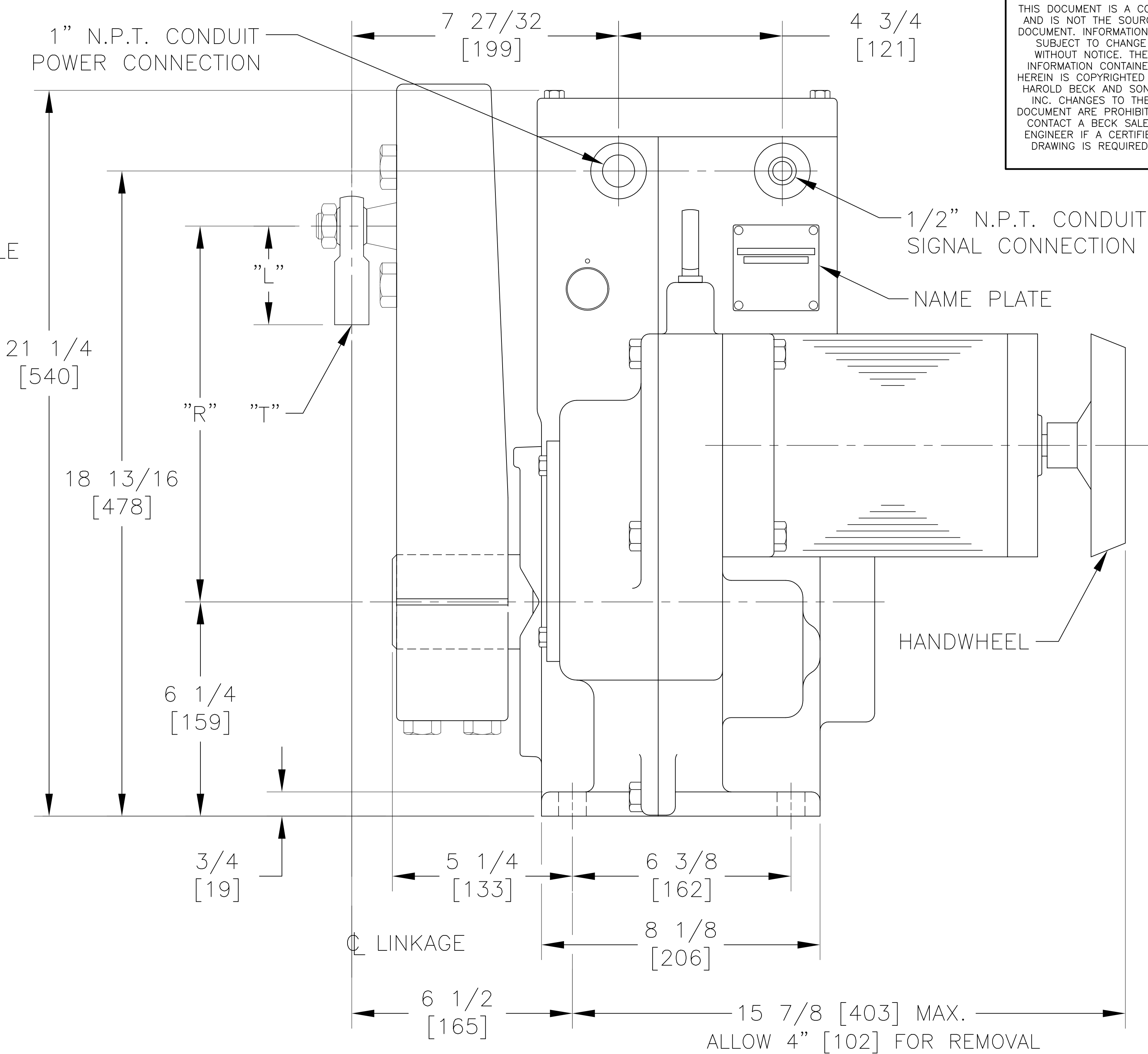
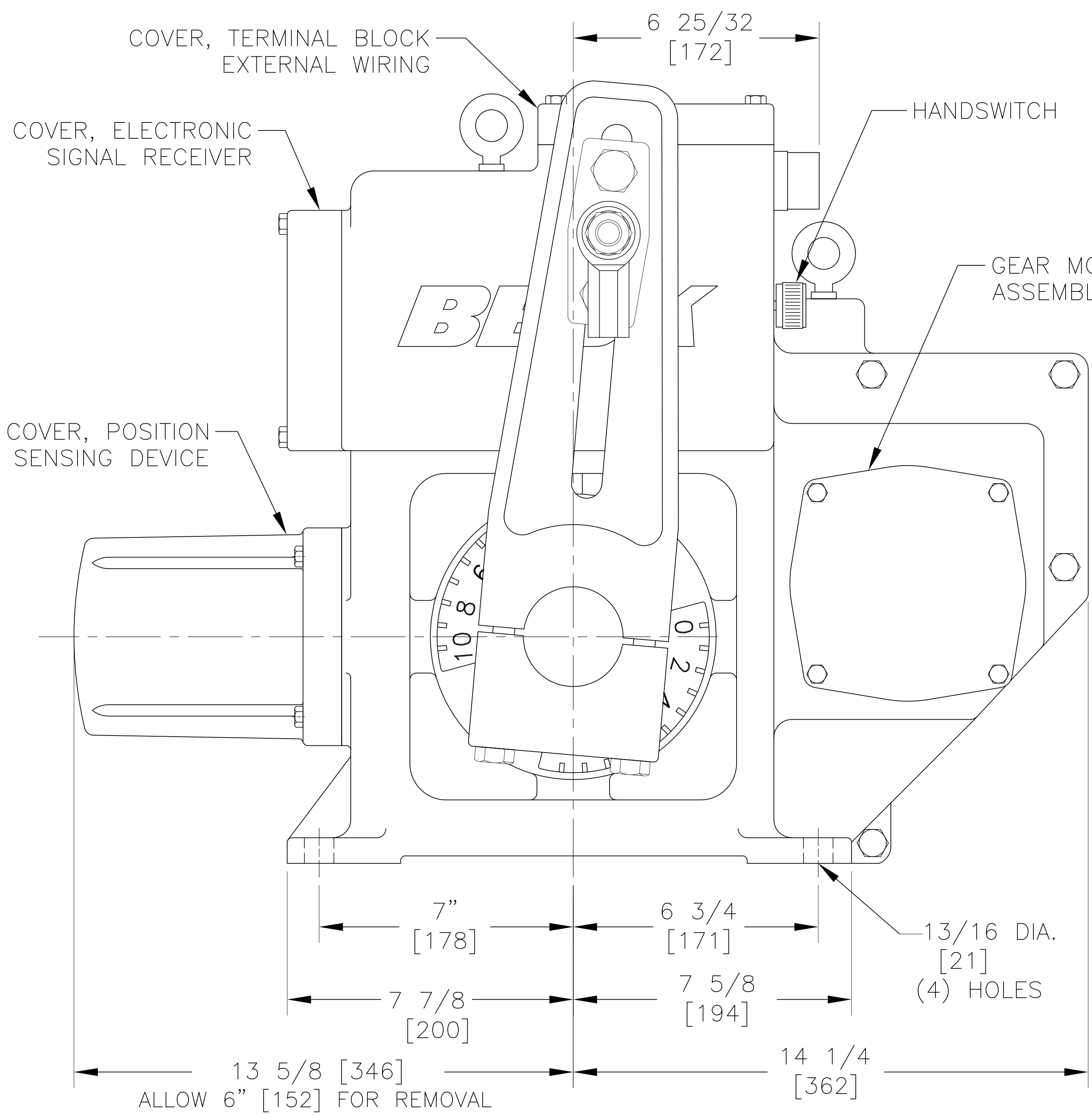

BECK DRIVE MODEL NO.	TORQUE RANGE	APPROX. WEIGHT	OUTPUT SHAFT DIA.	CRANKARM & SWIVEL SUPPLIED AS STANDARD				MAXIMUM OVERHUNG LOAD
				CRANKARM PART NO.	CRANKARM RADIUS (ADJUSTABLE) "R" DIM.	SWIVEL LENGTH "L" DIM.	SWIVEL INTERNAL THREAD "T" DIM.	
11-400	350 TO 1800 LB.-FT. 474 TO 2440 Nm	270 LBS. 122 KGS.	2 3/4 [70]	14-8018-02	6" TO 12" [152 TO 305]	2-7/8 [73]	3/4-16 X 1-3/4 [44]	9000 LBS. 4082 KGS.

RECOMMENDED SCREW TORQUES

	SIZE (IN.)	TORQUE (LB-FT)	TORQUE (Nm)
CRANK ARM SCREWS	5/8-18	170	230
CRANK PIN SCREW	3/4-16	300	407
ROD END LOCK NUT	3/4-16	120	163
BODY SCREWS	3/8-16	20	27
BODY SCREWS	1/2-13	50	68
COVER SCREWS	5/16-18	10	14
MOTOR SCREWS	3/8-16	16	22
GEAR MODULE SCREWS	5/16-18	10	14

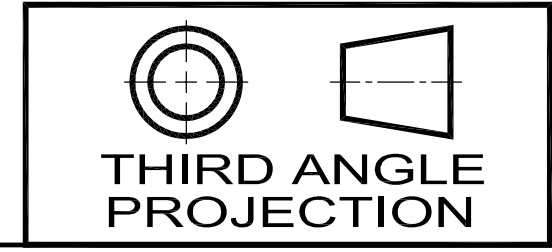

TOLERANCES:  
 OUTLINE DIMENSIONS ±1/4 [±6]  
 MOUNTING DIMENSIONS ±1/16 [±2]

ALL DIMENSIONS ARE IN INCHES AND [MM] UNLESS OTHERWISE SPECIFIED.  
 THREADS AND TAPPED HOLES ARE SPECIFIED AS UNIFIED THREAD SIZES ONLY.  
 CONDUIT PIPE THREADS PER AMERICAN NATIONAL STANDARD TAPER PIPE THREADS (N.P.T.)

**HAROLD BECK & SONS INC**  
 NEWTOWN INDUSTRIAL COMMONS NEWTOWN, PENNSYLVANIA 18940 USA

TITLE: **OUTLINE DIMENSIONS BECK 11-400 DRIVE**

DRAWN: DWK 10-24-07	SCALE: NONE	DRAWING NO: 18-0400-01o	REV: E
CHECKED: GMD 10-26-07			
APPROVED: JHM 10-26-07		SHEET NO. 1 OF 1	

18-0400-01o