

THIS DOCUMENT IS A COPY AND IS NOT THE SOURCE DOCUMENT. INFORMATION IS SUBJECT TO CHANGE WITHOUT NOTICE. THE INFORMATION CONTAINED HEREIN IS COPYRIGHTED BY HAROLD BECK AND SONS, INC. CHANGES TO THE DOCUMENT ARE PROHIBITED. CONTACT A BECK SALES ENGINEER IF A CERTIFIED DRAWING IS REQUIRED.

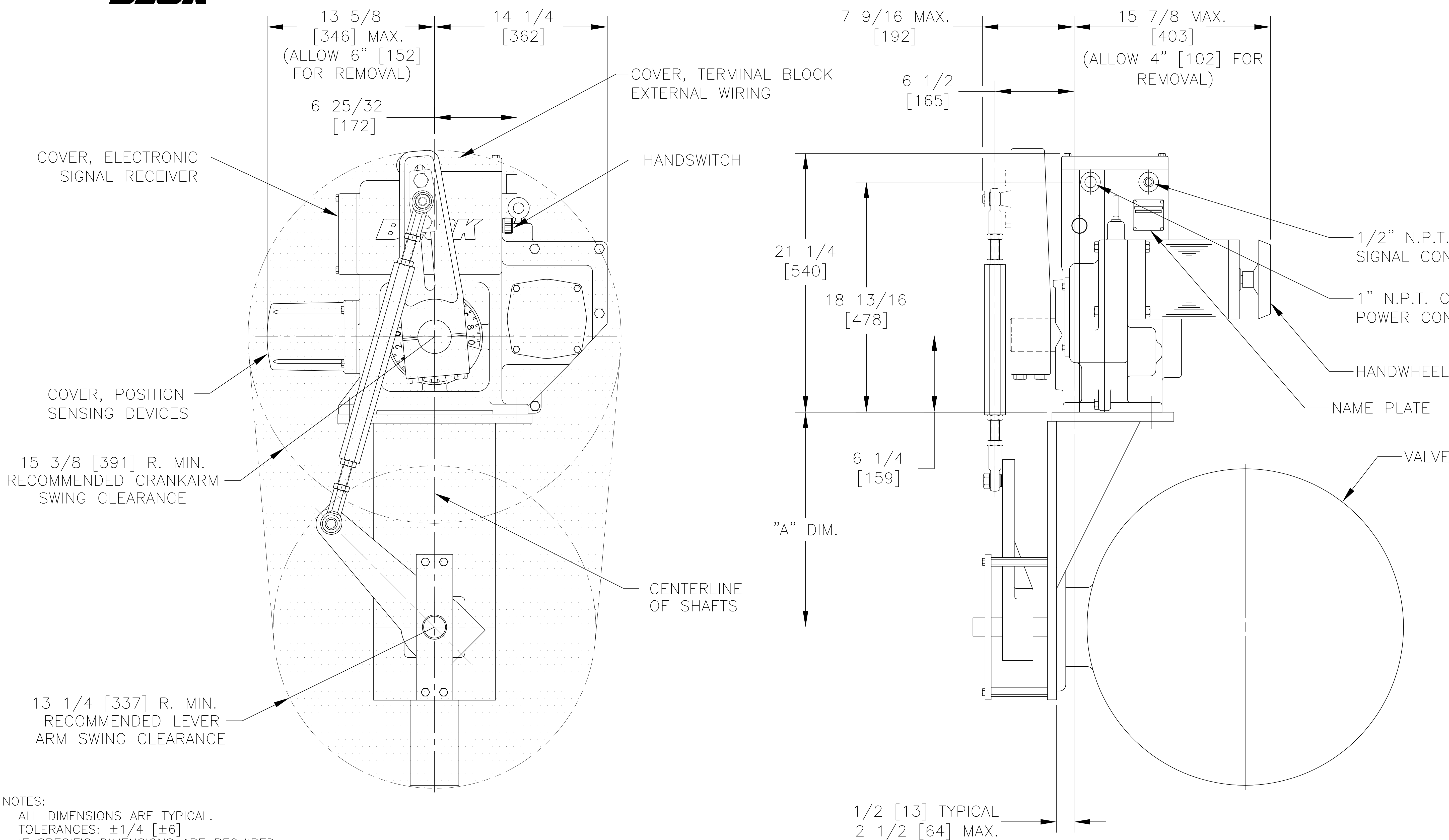

NOTES:
 ALL DIMENSIONS ARE TYPICAL.
 TOLERANCES: $\pm 1/4$ [± 6]
 IF SPECIFIC DIMENSIONS ARE REQUIRED,
 PLEASE CONTACT A FACTORY REPRESENTATIVE
 SCREW TORQUES FOR MOUNTING HARDWARE
 WILL BE SUPPLIED WITH SPECIFIC VMS.

ALL DIMENSIONS ARE IN INCHES AND [MM] UNLESS OTHERWISE SPECIFIED.
 THREADS AND TAPPED HOLES ARE SPECIFIED AS UNIFIED THREAD SIZES ONLY.
 CONDUIT PIPE THREADS PER AMERICAN NATIONAL STANDARD TAPER PIPE THREADS (N.P.T.)

VALVE SIZE	10"	12"	14"	16"	18"	20"	24"	30"	36"	42"	48"	54"
"A" DIM	11-1/2 [292]	11-1/2 [292]	12-1/2 [318]	14-1/2 [368]	14-1/2 [368]	16-1/2 [419]	16-1/2 [419]	16-1/2 [419]	18-1/2 [470]	19-1/2 [495]	22-1/2 [572]	24-1/2 [622]

	SIZE (IN.)	TORQUE (LB-FT)	TORQUE (Nm)
CRANK ARM SCREWS	5/8-18	170	230
CRANK PIN SCREW	3/4-16	300	407
ROD END LOCK NUT	3/4-16	120	163
BODY SCREWS	3/8-16	20	27
BODY SCREWS	1/2-13	50	68
COVER SCREWS	5/16-18	10	14
MOTOR SCREWS	3/8-16	16	22
GEAR MODULE SCREWS	5/16-18	10	14

18-0400-02o

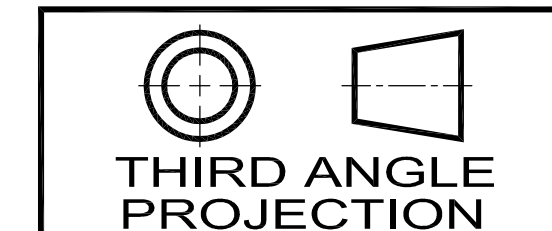

HAROLD BECK & SONS INC
 NEWTOWN INDUSTRIAL COMMONS NEWTOWN, PENNSYLVANIA 18940 USA

TITLE: **OUTLINE DIMENSIONS FOR UNITIZED ASSEMBLIES OF BECK 11-400 DRIVES & TYPICAL BUTTERFLY & BALL VALVES**

DRAWN: DWK 10-25-07	SCALE: NONE	DRAWING NO: 18-0400-02o	REV: B
CHECKED: GMD 10-26-07			
APPROVED: JHM 10-26-07		SHEET NO. 1 OF 1	

SIZE: D