

BECK[®]

ELECTRONIC CONTROL DRIVES

INSTALLATION GUIDE

Models 11-150, 11-200, 11-300, 11-400

A detailed Instruction Manual was included with this shipment.

This drive has been calibrated per the equipment order. No electrical adjustments are required.

If more than one drive was purchased, make sure the drive being installed is the correct torque, timing and rotation for the application. Refer to the inspection tag for drive information.

Do Not Remove Prior To Installation

Step 1: Design the Installation

Unless otherwise specified, the Beck drive will rotate 100°, while the damper may rotate 90° or less. Adjustments to start angles, radii, and linkage length will account for the different rotations. Benefits of 100° drive rotation are better control and a torque advantage. **Adjusting limit switches to reduce drive rotation should be done only as a last resort.** Contact Beck prior to adjusting limit switches.

Select a suitable mounting location that will allow for the following:

1. Clearance to remove drive covers.
2. A mounting base height to allow easy access and full 360° crank arm rotation.
3. The linkage to move through its full travel without interference.
4. The drive crank arm and damper lever arm to rotate in the same plane and the same direction. Do not use a “Z-Linkage” unless absolutely necessary. See page 8.
5. The wiring conduit to be run from below the drive to prevent water entry.

Obtain linkage design assistance (Link-Assist™) from Beck:

Provide the damper lever arm radius, start angle and stop angle. Also provide the horizontal and vertical offsets. See pages 7 and 8 for examples.

Contact Beck to obtain Link-Assist™ analysis for the crank arm radius, start angle, and linkage length.

Notes:

1. The drive can be mounted in any orientation.
2. The drive’s crank arm position is not preset.

Step 2: Design the Mounting Base

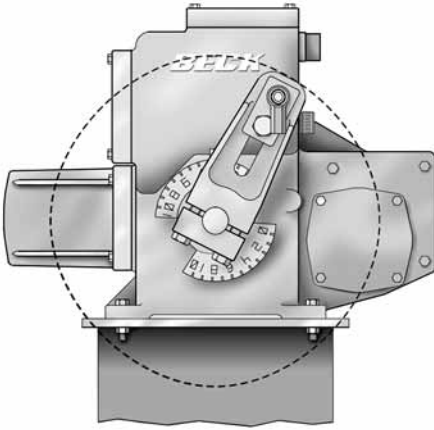

The mounting base should allow the crank arm to be positioned anywhere in the 360° rotation. This requires that the crank arm be able to rotate beyond the feet of the drive. This allows maximum freedom in designing the linkage.

The mounting base must not yield to the stresses created from operating the device.

The mounting plate should be at least as thick as the diameter of the mounting bolts.

The mounting plate must be flat.

Step 3: Mount the Drive

Place the drive on the mounting base. Ensure that all four mounting feet sit flat on the mounting plate. If necessary, add shims with the same surface area as the Beck mounting foot.

Caution: An uneven surface may result in cracking of the drive's mounting feet when the bolts are torqued.

Select the mounting bolts based on the following table:

MODEL	BOLT	TORQUE (lb-ft)
11-150	3/8-16 HHSZP GRADE 2 (or better)	20
11-200	5/8-11 HHSZP GRADE 2 (or better)	100
11-300	5/8-11 HHSZP GRADE 2 (or better)	100
11-400	3/4-10 HHSZP GRADE 2 (or better)	175

Step 4: Connect Power and Signal Wiring

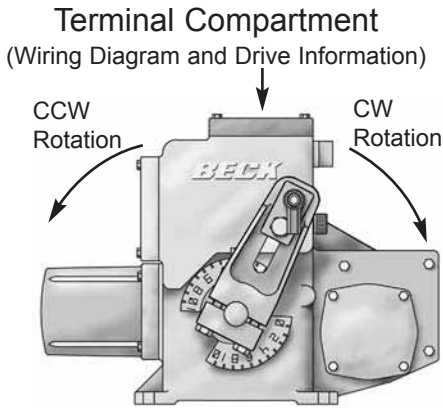

Route signal wires through the 1/2" NPT conduit connection, and route power and auxiliary switch wires through the 1" connection.

Connect all wires per the wiring diagram located inside the terminal compartment. Ground the drive at the provided grounding terminals.

Using a signal source, operate the drive to verify correct direction of rotation relative to the control signal. The direction of rotation can be reversed by following the "Changing Direction of Output Shaft Rotation" procedure in the appropriate Beck Instruction Manual 80-1100-03, Rev.10 (or later), or 80-1102-02 (option 9 drives).

Close covers immediately after installation. Torque cover bolts to 10 lb-ft.

Considerations:

For drives with a CPS-2 feedback device:

The CPS-2 position transducer provides a self-powered position signal. Wire only to controller inputs that do not provide the signal power ("4-wire type").

For drives with a film potentiometer feedback device:

The film potentiometer does not provide signal power. A dc voltage must be provided over the signal wires.

IMPORTANT: Prevent water entry into the drive—common causes of water entry include loose or missing covers, improperly sealed or routed conduit entrances, etc.

Step 5: Connect the Linkage

Note: For best results, the linkage arrangement should be designed in advance. Contact Beck for linkage kits and computer generated linkage calculations (Link-Assist™).

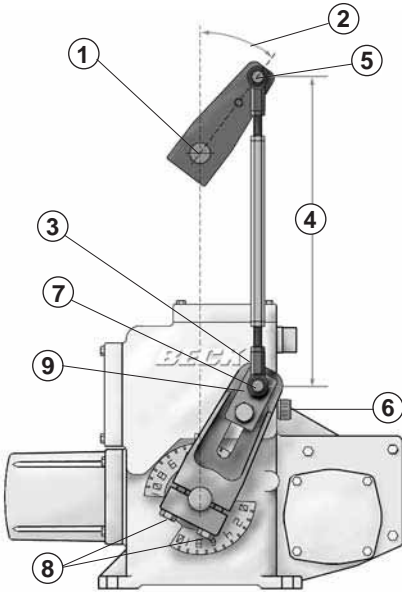

Step 1: Position the damper shaft to the closed position.

Step 2: Set the damper lever arm to its predetermined starting angle.

Step 3: Remove the rod end from the Beck crank arm and attach it to the connecting link.

Step 4: Adjust the connecting link to the predetermined length.

Step 5: Attach the connecting link to the damper lever arm at the predetermined radius.

Step 6: Use the Handswitch to run the drive to its fully closed starting position.

Step 7: Set the crank pin to the predetermined radius, then loosen the drive's crank arm bolts.

Step 8: Rotate the crank arm to its start position and bolt the rod end to the crank pin.

Step 9: Tighten fasteners enough to run the drive through its full travel. Ensure that the linkage does not bind. Note: If damper rotation is off, make adjustments to the crank arm and linkage. **Do not adjust travel limits (option 9 drives) or limit switches to compensate.**

Step 10: Once operation is satisfactory, tighten fasteners to the torques indicated in the following diagrams, and tighten the connecting link jam nuts.

Step 11: Lubricate the rod end bearings with an NLGI-1 E.P. (Extreme Pressure) rated grease.

Step 12: Set the Handswitch to the “Auto” position.

Crank Arm Bolt Torques

Model:11-150

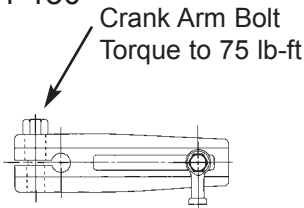

Rod End Bolt
Torque to 35 lb-ft

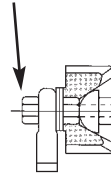

Rod End
Lock Nut
Torque to 55
lb-ft

Models:11-200/11-300

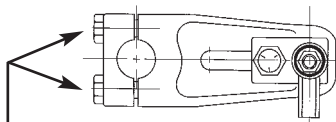

Crank Arm Bolts (2)
Torque to 240 lb-ft

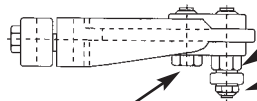

Crank Pin Stud
Torque to 300 lb-ft

Crank Pin Bolt
Torque to 300 lb-ft

Rod End Lock Nut
11-200 Torque to
35 lb-ft
11-300 Torque to
65 lb-ft

Model:11-400

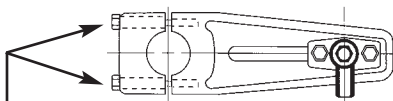

Crank Arm Bolts (4)
Torque to 170 lb-ft

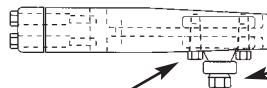

Crank Pin Bolt (2)
Torque to 300 lb-ft

Rod End
Lock Nut
Torque to
120 lb-ft

Examples of Typical Linkage Arrangements

(Obtain Link-Assist™ data from Beck)

Linkage Arrangement With a Horizontal Offset

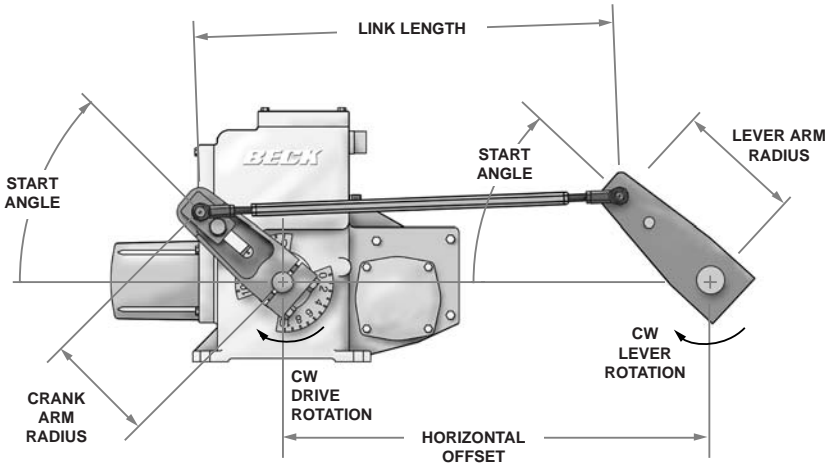

Linkage Arrangement With a Vertical and Horizontal Offset

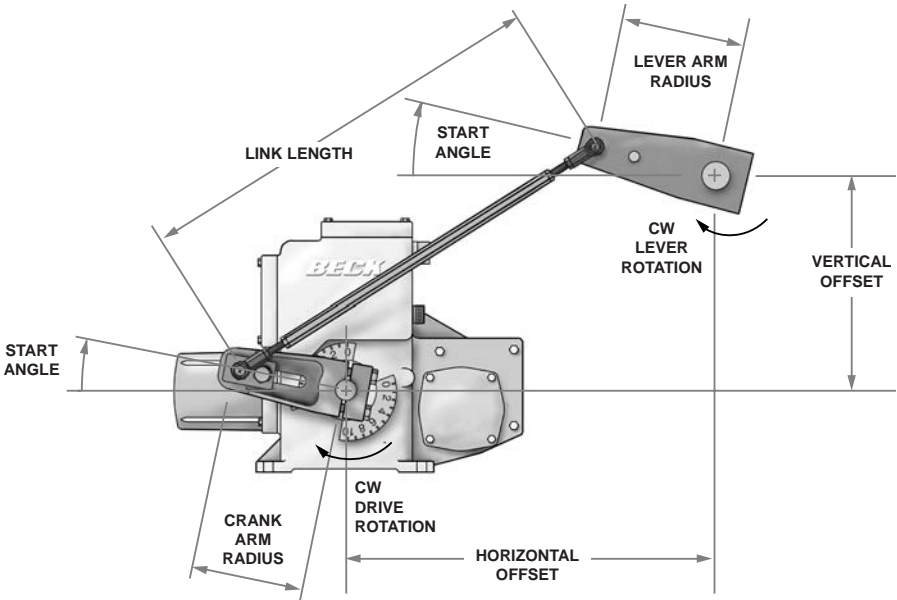

Counterclockwise Rotation Linkage Arrangement

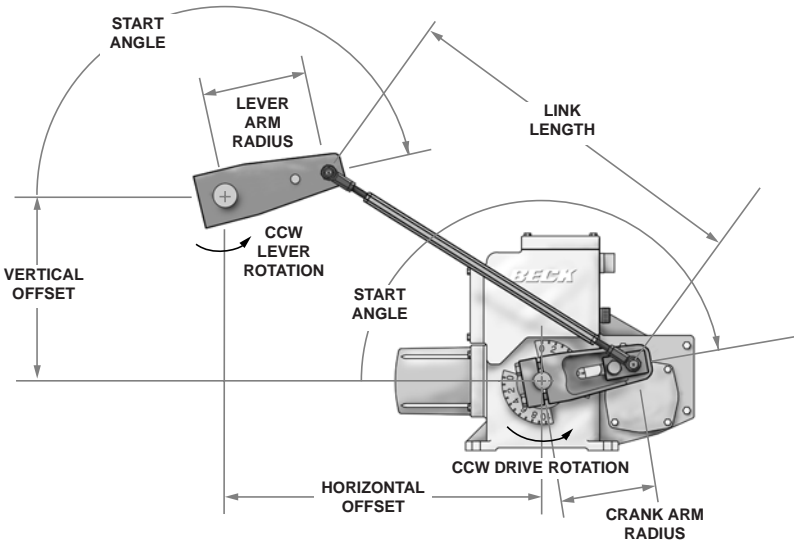

“Z-Linkage” Arrangement

The use of a Z-Linkage arrangement is not recommended.

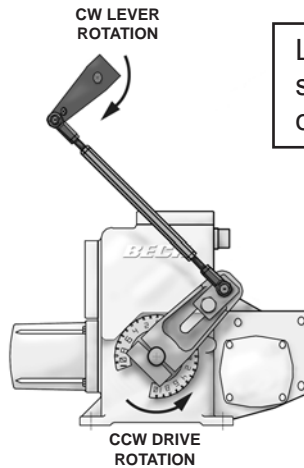

Load and drive shaft turn in opposite directions.

BECK[®] Harold Beck & Sons, Inc.
 11 Terry Drive • Newtown, PA 18940
 215-968-4600 • Fax: 215-860-6383
 E-mail: sales@haroldbeck.com
www.haroldbeck.com