

# **ELECTRICAL INSTALLATION GUIDE**

## **Group 22 Control Drives**

**A detailed Instruction Manual was included with this shipment.**

**The wiring diagram for this drive is located inside the terminal compartment.**

**This drive has been calibrated per the equipment order—no electrical adjustments are required.**

**If more than one drive was purchased, make sure the drive being installed is the correct torque, timing and rotation for the application. Refer to the inspection tag for drive information.**

**Do Not Remove Prior To Installation**

# Connect Power and Signal Wiring

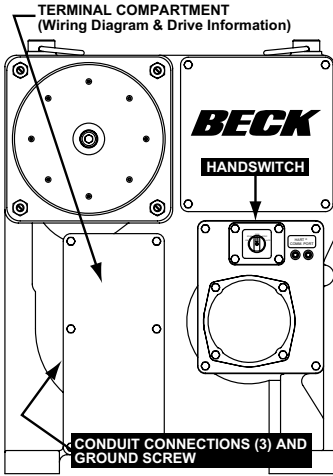

## Model 22-309/-409

(noted items are in the same general areas on model 22-809)

Route signal wires through the topmost 1" NPT conduit connection. Auxiliary switches and alarms should be wired through the middle 1" NPT conduit. Route power through the 1" NPT conduit closest to the bottom of the drive.

Connect all wires per the wiring diagram located inside the terminal compartment. Ground the drive at the provided grounding terminals.

Using a signal source, operate the drive to verify correct direction of rotation relative to the control signal. The direction of rotation can be reversed by following the directions for changing the output shaft rotation in Beck Instruction Manual 80-4280-02 (Note that the procedure for changing output shaft rotation differs depending on the Digital Control Module (DCM) type installed in the drive).

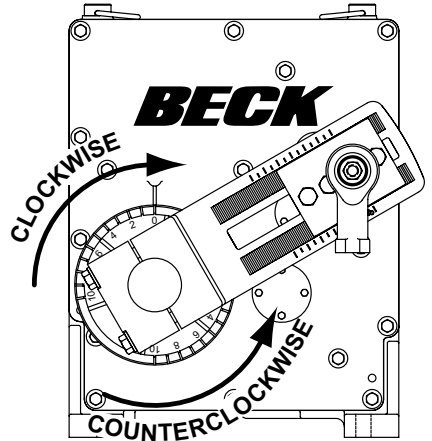

Close covers immediately after installation. Torque cover bolts to 10 lb-ft.

**IMPORTANT:** Prevent water entry into the drive—common causes of water entry include loose or missing covers, improperly sealed or routed conduit entrances, etc.

## Power Quality

Power quality is becoming an increasing concern in industrial processes today due to the necessity for equipment to include advanced electronics.

While Beck drives are designed to withstand demanding operating conditions and provide adequate protection against power quality disturbances (meets the requirements of IEC-61000-6-2, Immunity Standard for Industrial Environments), it is recommended that the supply power provided to your drive be conditioned such that an electrical supply disturbance outside of the normal operating specifications will not interrupt drive operation, degrade drive performance, or damage drive components.

Examples of power quality disturbances that are realized throughout industry today include power outages, transient voltages, harmonic distortions, and electrical noise. Since it is impossible to prevent all disturbances from occurring, increasing the protection of your equipment can reduce downtime and will promote a longer lifetime for your equipment. The following recommendations are provided for you to maximize the protection of your Beck electronic control drive.

- Select wiring materials according to the correct ampacity ratings dictated by national and local regulations.
- Shielded twisted pair cables should be used for signal connections to avoid being affected by electrical noise. A braided shield will be more effective than a wrapped foil shield. Signal wire shields should be connected to the drive casting grounding screw. If grounding at the signal source is required, then the shield should not be grounded at the drive.

Continued ...

## **Power Quality (continued)**

- An AC power ground connection must be made between the power source and the Beck drive. Grounding connections including wire and metal conduit are permitted, with the exception that the equipment-grounding conductor may not be connected to a structured metal frame of a building.
- Surge suppression equipment that meets Underwriters Laboratory (UL) Standard 1449 may be used to protect against transient voltage conditions.
- Power Conditioners may be used to regulate the supply voltage to maintain a constant voltage level. They are helpful in protection against voltage sags and swells, as well as an extra measure to reduce the amount of electrical noise that your drive will see.
- Harmonic filters may be used to minimize the effects of supply voltage waveform distortions and are used in applications that incur a large amount of high-frequency electronic noise.

**BECK<sup>®</sup>**

**HAROLD BECK & SONS, INC.**

2300 TERRY DRIVE • NEWTOWN, PENNSYLVANIA 18940 • USA

PHONE: 215-968-4600 • FAX: 215-860-6383 • E-MAIL: [sales@haroldbeck.com](mailto:sales@haroldbeck.com)

03/04