

BECK[®]**REPLACEMENT INSTRUCTIONS****HANDSWITCH
REPLACEMENT KIT P/N 12-8064-09****PURPOSE**

The purpose of these instructions is to provide the field maintenance technician with a step-by-step method for replacing the Handswitch on the Beck 42-109 control drive. The Handswitch is a non-wear item that only requires replacement if physically damaged. The hardware supplied with this kit is listed in Table 1. The Handswitch assembly is completely interchangeable electrically and mechanically with the previous open contact-type assembly. It also uses the same wiring color code to simplify electrical installation.

Maintenance to the Group 42 should be performed in a clean working environment. If possible, the drive should be removed from its mounting point and taken to a maintenance room or workstation.

REQUIRED TOOLS

1/2" socket or wrench
 5/64" hex driver
 #1 Phillips head screwdriver
 Torque wrench appropriate for 10 lb-ft
 Torque screwdriver appropriate for 10 lb-in
 Wire cutters / strippers
 Crimping tool
 Loctite[®] Threadlocker 222 MS or equivalent
 Scotch[™] 847 gasket adhesive or equivalent

WARNING

Electrical shock hazard—disconnect power before proceeding. Remove the drive from line voltage and shut off any external power sources feeding the auxiliary switches.

PROCEDURE

Removal of the old Handswitch assembly:

Refer to Figures for component identification.

1. Remove power from the drive.
2. Remove the terminal enclosure cover by loosening the (6) 5/16"-18 hex head captive screws.

3. Remove the Handswitch knob. The knob is held onto the Handswitch shaft by (2) #8-32 socket set screws. Loosen but do not remove these set screws from the Handswitch knob.
4. Remove the (2) #6-32 Phillips head screws from the Handswitch adaptor.
5. Pull the Handswitch assembly free of the terminal enclosure, to allow access to the wiring of the Handswitch. Pull the Handswitch assembly far enough away from the enclosure to allow uninhibited access to the wires, but be careful that excessive strain is not placed on the wire connections in the drive.
6. Cut the wires from the old Handswitch assembly, leaving enough length on the old wiring to allow them to be spliced to the new Handswitch assembly. Discard the old switch assembly.

Installation of the new Handswitch assembly:

7. Strip approximately 1/4" of insulation off the end of each wire from the drive.
8. Retrieve the new Handswitch assembly. Note that it may be necessary to remove the knob from the new assembly.
9. Using the provided wire joints, splice the wires of the new Handswitch assembly color-to-color with the old wiring of the drive.
10. Push the Handswitch assembly back into the terminal enclosure and install the (2) #6-32 Phillips head screws into the Handswitch adaptor. Orient the pin on the Handswitch adaptor towards the extension tube of the drive. Torque the screws to 10 lb-in.
11. Install the knob onto the Handswitch. Hand-tighten both #8-32 socket set screws. Ensure that "Extend", on the knob, is oriented properly to the flat on the Handswitch shaft and the pin on the Handswitch adaptor.

Continued

12. Inspect the terminal enclosure cover gasket; replace as necessary. If the gasket is in good condition, skip to step 16.
13. Clean the mating face on the drive body and terminal enclosure cover to remove all gasket material and adhesive. Ensure that the mating surface is free of defects such as dents or gouges.
14. Apply a thin film of gasket adhesive (Scotch™ 847 or equivalent) to the mating face of the drive body.
15. Firmly press the new gasket into place and allow time for the adhesive to set before continuing.

16. Reinstall the terminal enclosure cover and tighten the (6) 5/16"-18 hex head captive screws to 10 lb-ft torque.
17. If the drive has been removed from its mounting location, remount the drive.
18. Return power to the drive and observe to make sure that the Handswitch and the drive operate properly. Place the Handswitch at each setting and ensure the drive responds properly.
19. Return the drive to service.

Table 1: Handswitch Replacement Kit

| Part Number | Description |
|-------------|--|
| 20-3300-37 | Handswitch Assembly, Ret/Ext 2 Pole, 5 Position 30 Degree Index |
| 20-0032-01 | Wire Joints (5) |
| 20-0660-76 | Gasket, Enclosure Cover |

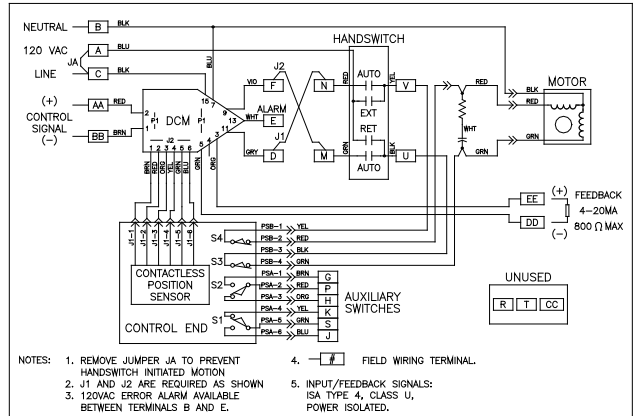

Figure 2

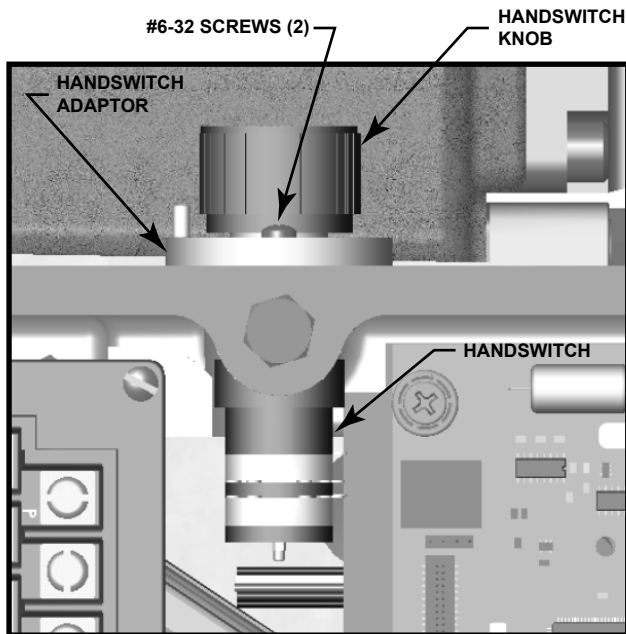

Figure 1

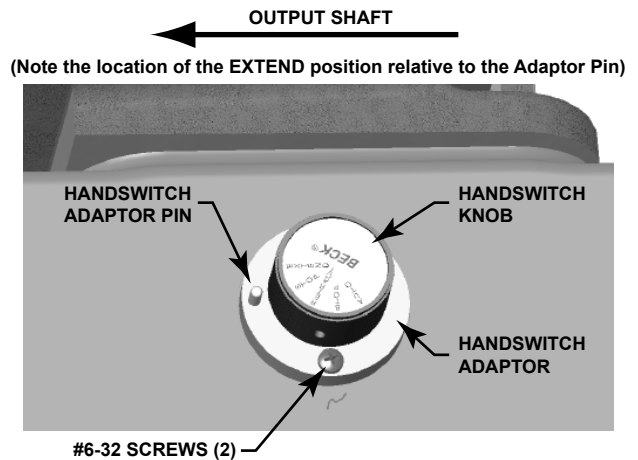

Figure 3