

**BECK**<sup>®</sup>

## SUPPLEMENT TO THE DRIVE SPECIFICATION GUIDE

---

---

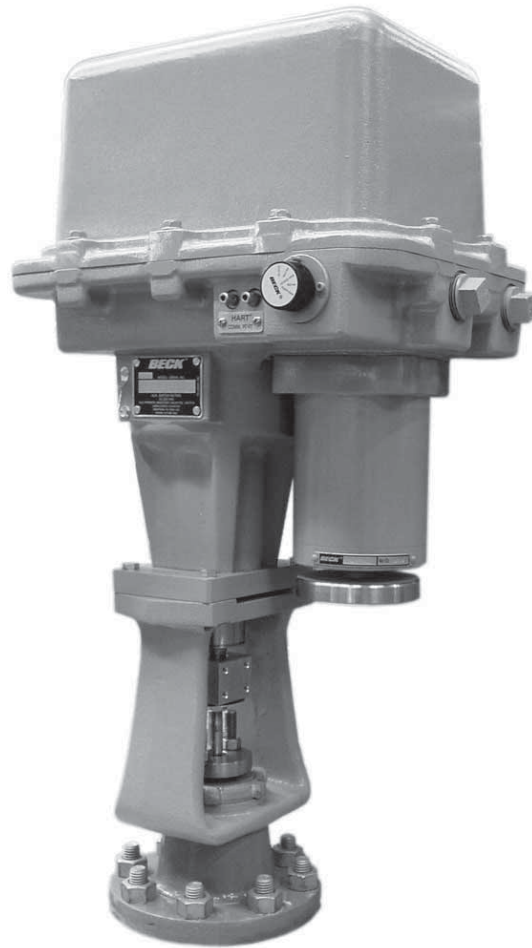

**A versatile design, advanced HART<sup>®</sup>-capable electronics, hazardous location ratings and Beck reliability all highlight the new Group 29 linear valve drive.**

Beck's all-new Group 29 linear valve drive improves upon the time-honored Group 14 product line. It is designed to provide precise, reliable control of all types of modulating globe valves. The Group 29 offers the excellent performance and maintenance-free design typical of all Beck drives, as well as the flexibility and advanced features provided by microprocessor-based electronics.

Ideally suited for process control applications in even the harshest environments, the Group 29 handles valve thrust requirements up to 6,100 lbs. and is easily mounted on most valves. A ball screw design combined with a new patented control algorithm and the traditional Beck motor design ensure repeatable modulation as precise as 0.1% of span. Available custom hardware design makes installation simple, while the rugged, weatherproof body rated for hazardous locations ensures safe operation in almost any plant environment.

## GENERAL SPECIFICATIONS

### Output Thrust and Timing

Model No.	Thrust (lbs.)	Stroke Timing (seconds/inch)	Minimum Stroke Length	Maximum Stroke Length
29-100	1000	10	0.50"	2"
29-250	1700	10	0.50"	2"
29-250	2100	12.4	0.50"	2"
29-250	2700	15	0.50"	2"
29-600	2100	9.4	0.75"	4"
29-600	2600	11.6	0.75"	4"
29-600	3200	14	0.75"	4"
29-600	4100	9.4	0.75"	4"
29-600	5000	11.6	0.75"	4"
29-600	6100	14	0.75"	4"

Drive Power	120 V ac, single-phase, 50 or 60 Hz 240 V ac, single-phase, 50 or 60 Hz
Weight	29-100 -- approx. 94 lbs., including yoke 29-250 -- approx. 145 lbs., including yoke 29-600 -- approx. 220 lbs.
Operating Conditions	-40° to 85°C (-40° to 185°F) 0 to 99% relative humidity
Communication Protocols	HART® or Foundation Fieldbus™ technology. Contact a Beck Sales Engineer for details and information regarding other options.
Demand Input Signal Range	4–20 mA, 1–5 V dc
Minimum Step	0.1% of span
Hysteresis	0.25% of span at any point.
Demand Input Signal Linear Characterization	Linear: Drive output shaft moves proportionally to the input signal. Square: Drive output shaft moves proportionally to the square of the input signal. Custom: 20 segment configurable curve fit
Position Feedback Signal	4–20 mA
Isolation	Demand input and position Feedback signals are isolated from ground and the ac power line. Signal buffering provides 24 V dc isolation between the Demand and Feedback signals.
Action on Loss of Power	Output shaft stays in last position.
Action on Loss of Input Signal (Power on)	Stay in place or runs to any preset position (configurable).
Over-thrust Protection	If the output thrust of the drive exceeds 115% of the drive rating, the motor will shut off (feature can be enabled/disabled).
Stall Protection	If the motor tries to run in one direction for more than 300 seconds (configurable from 30 to 300 seconds), the motor will shut off.

Over-travel Limit Switches

Two Form C (Retract and Extend) provide over-travel protection.

Auxiliary Switches (Field adjustable)

Two Form C and two Form A, rated for 1 A, 250 V ac.

Handswitch

Permits local electrical operation, independent of Demand input signal.

Handwheel

Provides manual operation without electrical power.

Enclosure

Precision-machined aluminum alloy castings, painted with corrosion-resistant polyurethane paint, to provide a rugged, dust-tight, weatherproof enclosure designed to meet NEMA 4X standards.

Mounting Orientation

Can be mounted in any orientation.

Typical Wiring Diagram, Model 29-XX9, 120 V ac Operation

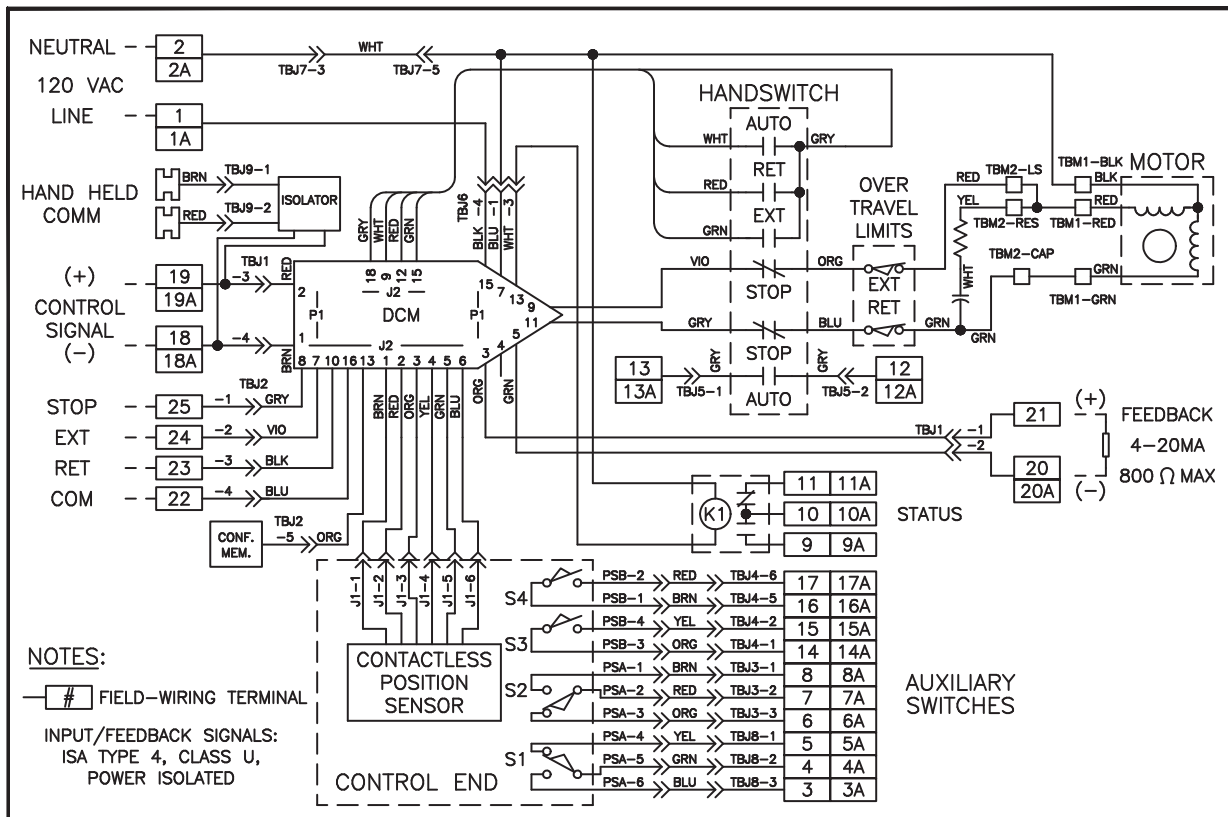

## FEATURES

The Group 29 drive combines years of valve actuation experience with the latest technologies to provide all of the performance and reliability customers expect from Beck drives in a very flexible and easy-to-use package.

### Hazardous Location Approval Ratings

In addition to the ordinary agency location approvals, the Group 29 can be rated for hazardous locations as well. Contact the factory for available classifications.

### Control & Operating Features

In addition to controlling the precise modulation of the drive, the advanced Digital Control Module (DCM-2) provides a host of features and functions. Some of the advanced features include:

- A patented positioning algorithm that ensures repeatable valve positioning down to 0.1% of span.
- Live thrust measurement and over-thrust protection.
- Two-way digital communications via HART® protocol. Foundation Fieldbus™ is also available.
- Simple calibration and setup without any mechanical or electrical adjustments.
- 20-segment configurable demand input signal characterizer.
- Multiple drive diagnostic capabilities with time stamping and an onboard real time clock.
- Configurable action on loss of demand input signal.
- Stall protection with configurable stall time setting.
- Operating variables, including temperature, can be displayed via HART®.
- The ability to restore all drive calibration and setup to the factory "as-built" settings.

### Electrical features

**No burnout motor:** The Group 29 utilizes a low current draw, continuous duty motor design. The drive's onboard control electronics (DCM-2) directly feed the motor windings, thus eliminating external motor starters and controls completely. In addition, the motor will not coast or overshoot and will not overheat—even under continuous modulation.

**Handswitch:** Similar to all Beck drives, the Group 29 is equipped with an electrical override Handswitch to aid in setup and installation of the drive independent of external control signals.

**Auxiliary switches:** Two non-dedicated Form C and Form A switches are standard. These switches are cam-operated and easily adjusted in the field. Wiring connections are provided in the drive terminal compartment to allow easy access.

### Mechanical Features

**Gear train:** The Group 29 utilizes a high-efficiency gear train designed for high performance, long life and minimal wear. It consists of a combination of precision-cut alloy steel and ductile iron spur gears and a precision ball screw.

**Self-Locking Mechanism (SLM):** A self-locking mechanism is an integral part of the Group 29 drive system. The SLM is a coupling that transmits motor torque to the gear train, but instantly locks in place when the motor is de-energized. This prevents back-driving due to dynamic valve load.

**Manual operation:** Group 29 drives can be manually operated, without power, by a Handwheel attached directly to the motor shaft.

**Tight-Seater™:** Group 29 valve drives are equipped with a Tight-Seater™ device that ensures the valve is positively seated at the closed position.

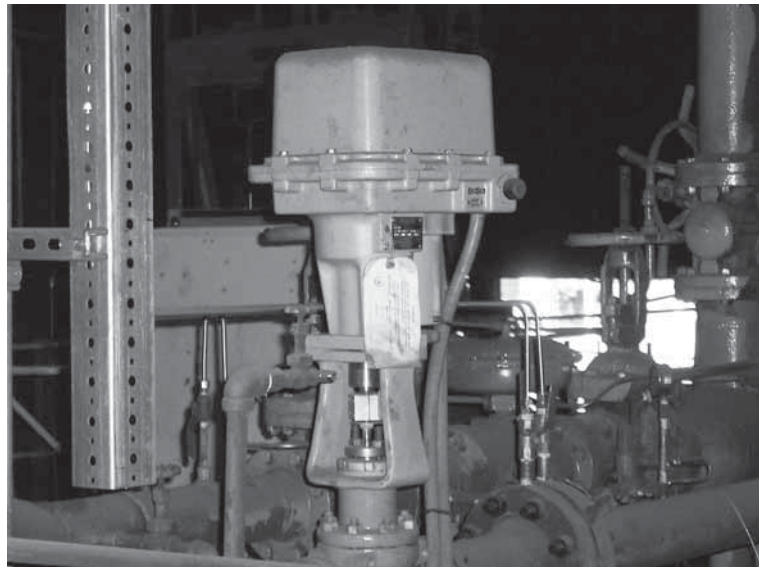
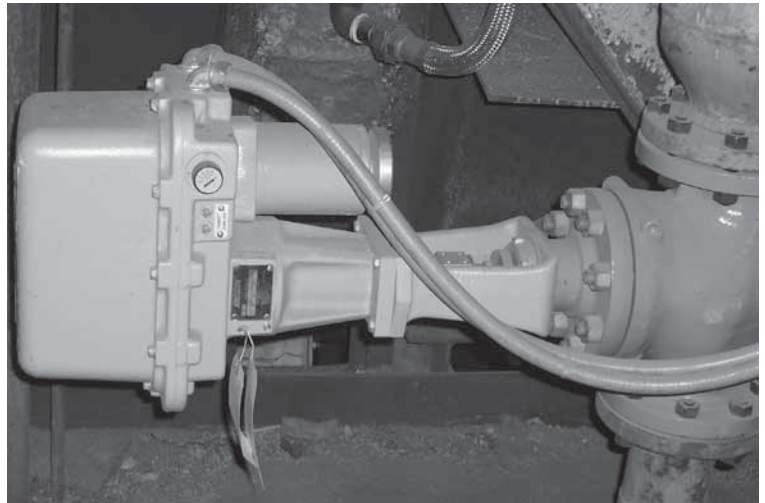
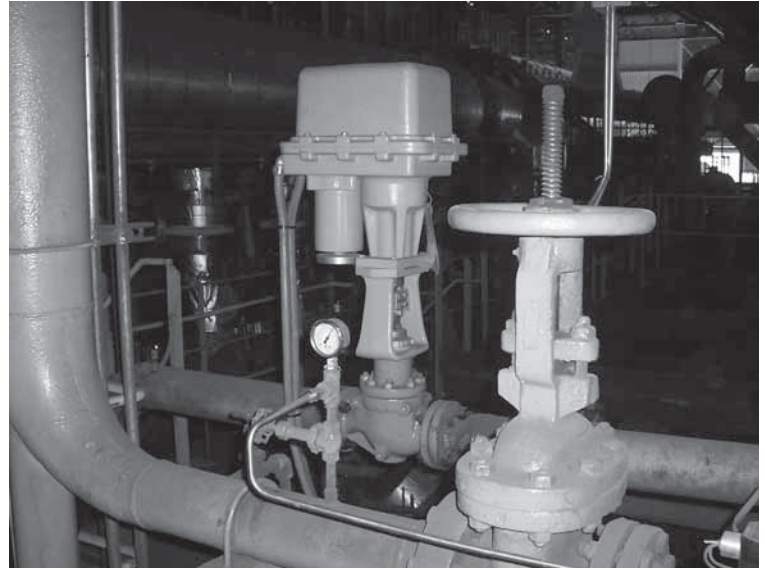
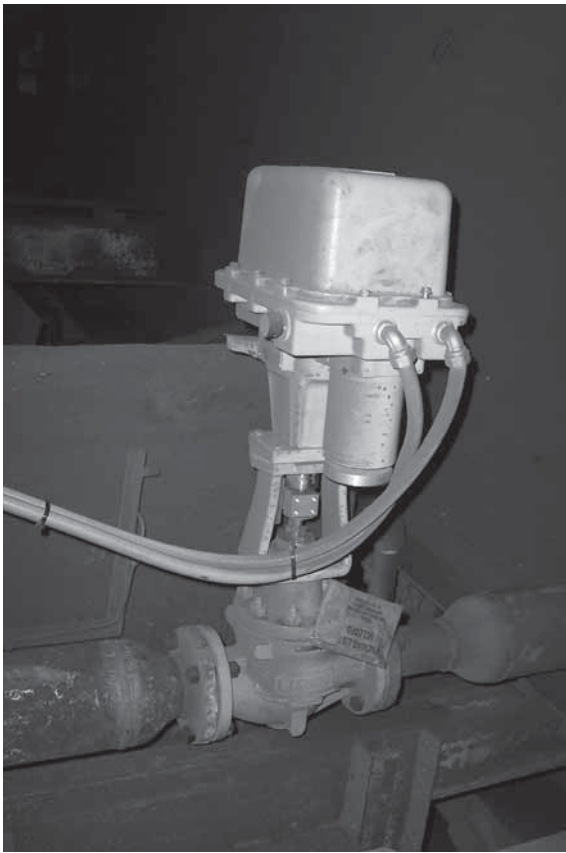

**Contact a Beck Sales Engineer to find out more about the Group 29 product line of Electronic Control Drives.**

**GROUP 29 OUTLINE DIMENSIONS**

**29-100**

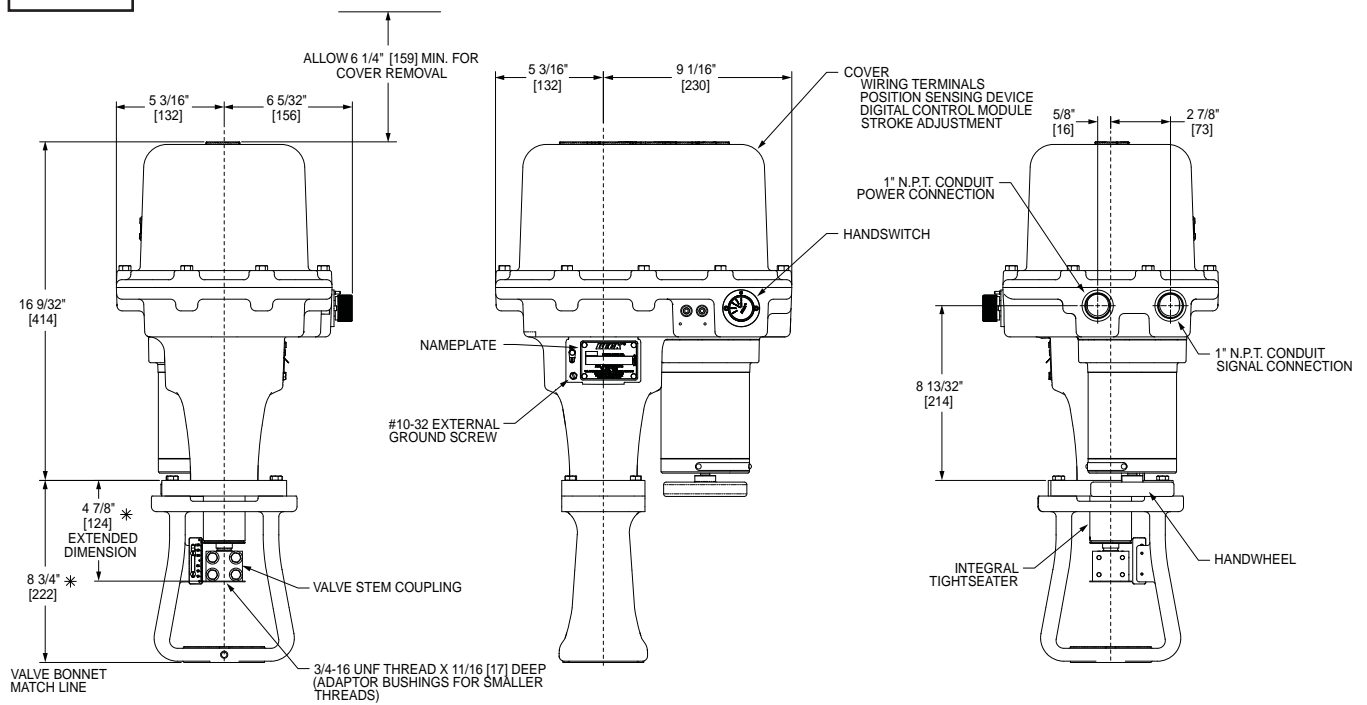

**29-250**

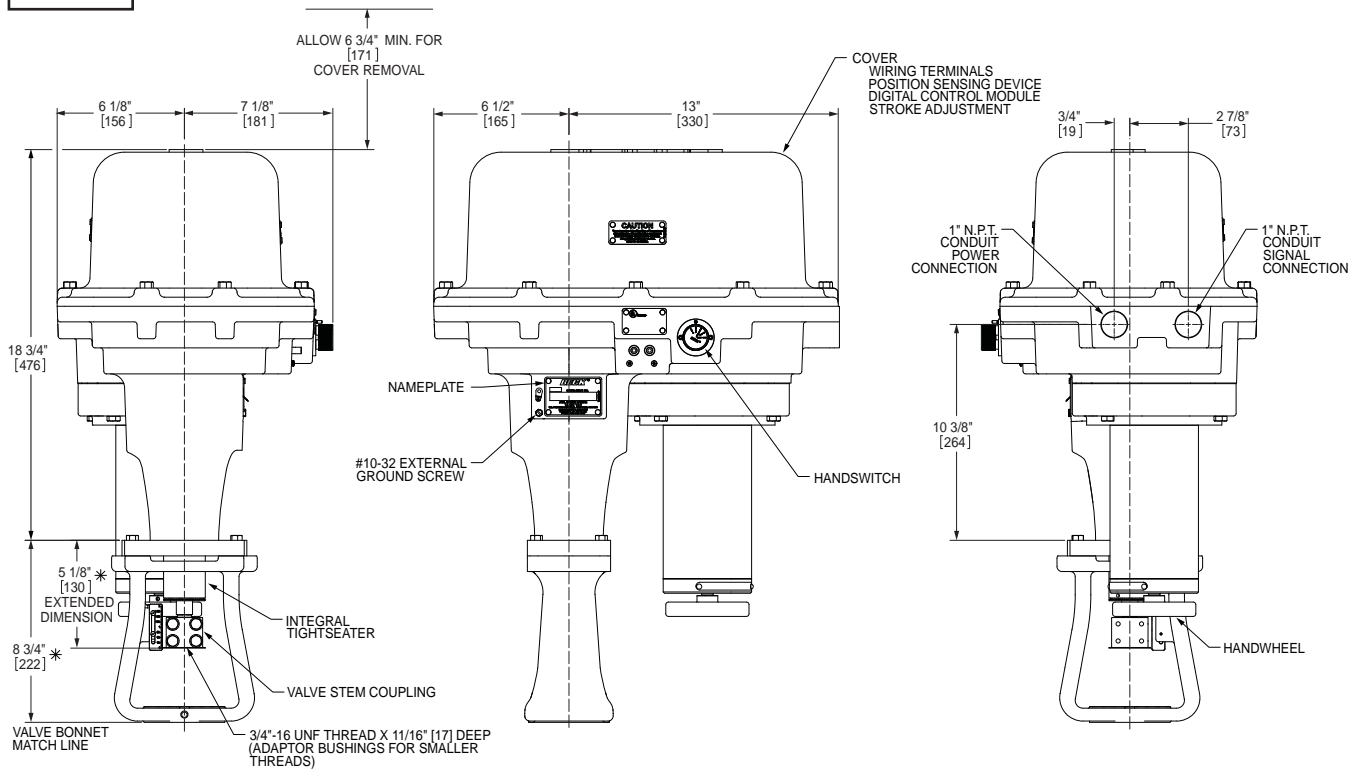

\* TYPICAL MOUNTING FEATURE -- MAY VARY PER APPLICATION

ALL DIMENSIONS ARE IN INCHES AND [MM]

ALL DIMENSIONS ARE SUBJECT TO CHANGE

THE ORIENTATION BETWEEN THE DRIVE AND MOUNTING YOKE MAY NOT BE CHANGED

29-600

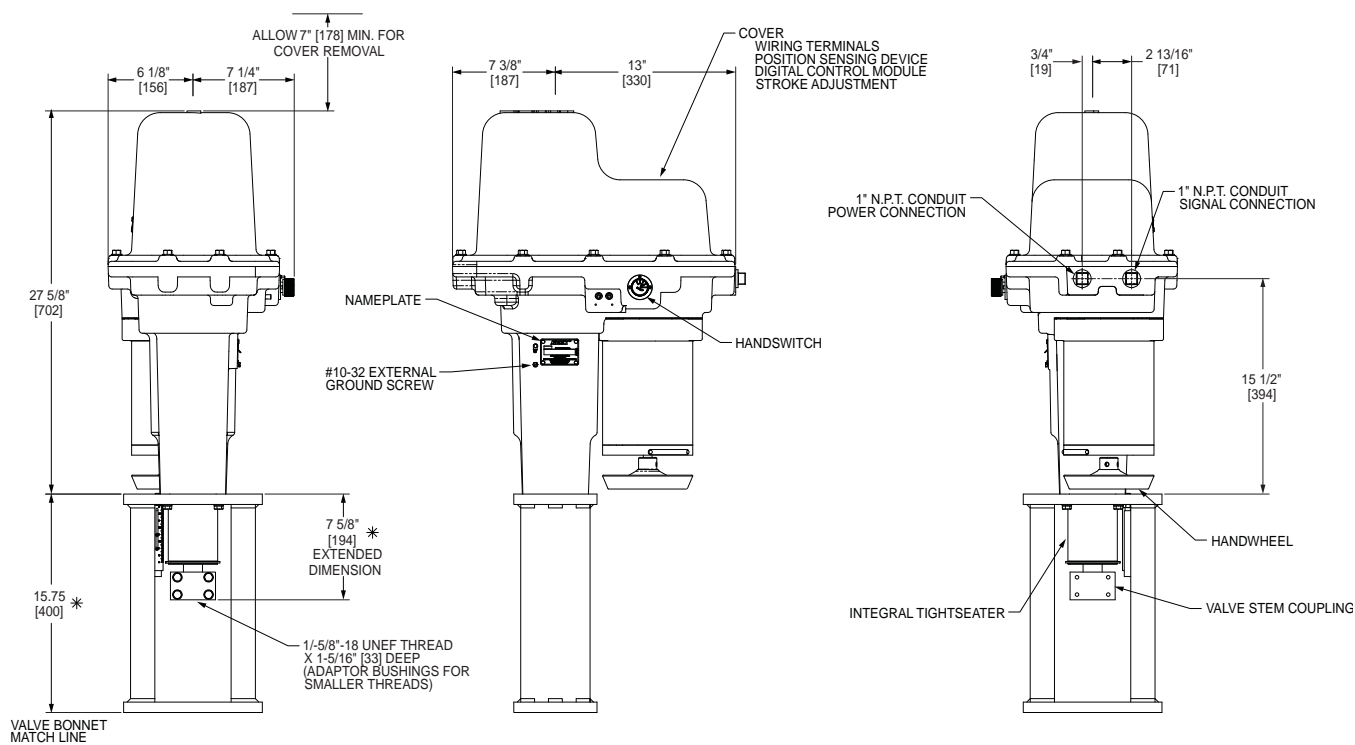

\* TYPICAL MOUNTING FEATURE -- MAY VARY PER APPLICATION

ALL DIMENSIONS ARE IN INCHES AND [MM]

ALL DIMENSIONS ARE SUBJECT TO CHANGE

THE ORIENTATION BETWEEN THE DRIVE AND MOUNTING YOKE MAY NOT BE CHANGED

**BECK<sup>®</sup>** **HAROLD BECK & SONS, INC.**

11 TERRY DRIVE • NEWTOWN, PENNSYLVANIA 18940 • USA  
PHONE: 215-968-4600 • FAX: 215-860-6383 • [www.haroldbeck.com](http://www.haroldbeck.com)